

INDUSTRIAL TUMBLE DRYER

T
RANGE

T 11	TAMS13	T 13	T 13/13	T 16
11KG 24LB	13KG 27LB	13KG 20LB	2X13KG 2X27LB	16KG 35LB



FEATURES

- Standard stainless steel drum with large diameter
- Easy-to-use microprocessor (ECT)
- Combination of Radial and Axial airflow - RADAX® concept:
 - maximal heat transfer
 - low energy consumption
 - short drying time
- Large door opening for easy loading and unloading
- Self cleaning lint screen

OPTIONS

- Coin operated version
- Reversing drum
- Full Control programmer (FCT)
- Residual moisture control Sensodry®:
 - safe drying of delicate linen
 - humidity detection in %
 - ideal in combination with SoftWash®
 - ideal for dry cleaners, fire depts
 - available on Easy and Full Control
- Stainless steel front

T 13/13



TAMS13

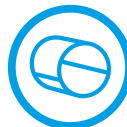

STANDARD
STAINLESS STEEL
DRUM



LARGE DOOR
OPENING



ENERGY
EFFICIENT



GET AHEAD IN LAUNDRY

TYPE		T11	TAM13	T13	T13/13	T16
CAPACITY						
Drum capacity	kg/lb	11/24	13/27	13/27	2x13/2x27	16/35
Drum volume	l	250	285	285	2x285	345
Drum diameter	mm	Ø 760	Ø 760	Ø 760	2xØ 760	Ø 760
Number of drums		1	1	1	2	1
Number of loading doors		1	1	1	2	1
AIRFLOW	m ³ /h	520	550	550	1050	600
DRYING AVERAGE	l/min.	190	225	225	2x225	300
MOTORS						
Fan	kW	0,55	0,75	0,55	2x0,75	0,55
Drive	kW	0,25	0,25	0,25	2x0,25	0,25
GAS HEATING						
Gas connection	NPT	3/4"	3/4"	3/4"	2x3/4"	3/4"
Electrical connection		3x220-240V 50Hz, 1x220-240V 50Hz, 3x380-415V 50Hz				
Energy	kW	16,5	19,5	19,5	2x19,5	25
	kBTU/h	56,3	66,5	66,5	2x66,5	85,3
STEAM HEATING						
Steam connection	NPT	3/4"		3/4"	3/4"	3/4"
Electrical connection		3x220-240V 50Hz 1x220-240V 50Hz 3x380-415V 50Hz		3x220-240V 50Hz, 1x220-240V 3x380-415V 50Hz		
Steam output *	kW	16,5-22		19,5-27	2x19,5-27	22-32
Steam pressure	bar	3-6/7-10		3-6/7-10	3-6/7-10	3-6/7-10
ELECTRICAL HEATING						
Electrical connection		3x220-240V 50Hz, 3x380-415V 50Hz, 3x480V 60Hz				
Energy	kW	13,5	18,0	18,0	2x18,0	24,0
PROGRAMMER						
Easy control - antivandal (ECT)		Standard	Standard (No coin)	Standard	Standard	Standard
Full control (FCT)		Available	Available	Available	Available	Available
EXHAUST	mm	200				
DIMENSIONS						
H×W×D	mm	1680x795x1070	1075x795x1240	1680x795x1160	2030x795x1240	1680x795x1280
Net weight	kg	230	185	250	370	250
TRANSPORT DATA						
Packed H×W×D	mm	1785x855x1100	1160x880x1325	1785x855x1190	2120x880x1325	1785x855x1310
Gross weight	kg	240	200	265	385	270

* Steam output is flexible depending on steam pressure, The data concerning dimensions of machines include all extended parts

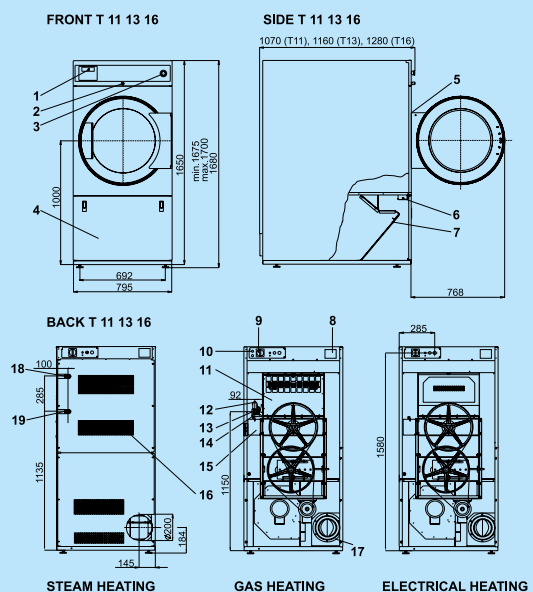

1. Programmer
2. Lock of the control panel
3. Emergency stop button (not applicable for version with coin meter)
4. Lint screen cover
5. Door lock microswitch
6. Lint cover microswitch
7. Lint screen
8. Name plate
9. Main switch
10. Main power supply
11. Heating chamber
12. Gas valve (G models only)
13. Pressure regulator (G models only)
14. Gas supply (G models only)
15. Airflow switch
16. Suction
17. Exhaust piping
18. Steam supply
19. Condense drain

The Primus preserves the right to change the machines and the specification in this leaflet at any time, without prior notice. Details and photographs are only for information and never binding.

www.primuslaundry.com

Primus by Alliance Laundry Systems

